

Infrared Remote-Control Receiver Module

Technical Data Sheet

Part No.: M6038



Features:

- Photo detector and preamplifier in one package.
- Photodiode with integrated circuit.
- Internal filter for PCM frequency.
- Improved shielding against electrical field disturbance.
- High protection ability against EMI.
- High immunity against ambient light.
- High sensitivity.
- Low voltage and low power consumption.
- Long reception distance.
- Circular lens to improve the receive characteristic.
- TTL and CMOS compatibility.
- Output active low.
- Line-up for various center carrier frequencies.
- The product itself will remain within RoHS compliant version.

Descriptions:

The M6038 series are miniaturized receivers for infrared remote control systems. PIN diode and preamplifier are assembled on lead frame, the epoxy package is designed as IR filter. The demodulated output signal can directly be decoded by a microprocessor. The benefit is the reliable function even in disturbed ambient and the protection against uncontrolled output pulses.

The M6038 series is the standard IR remote control receiver series, supporting all major transmission codes.

Applications:

- Optical switch.
- Light detecting portion of remote control.
- AV instruments such as Audio, TV, VCR, CD, MD, etc.
- Home appliances such as Air-conditioner, Fan, etc.
- The other equipments with wireless remote control.
- CATV set top boxes.
- Multi-media Equipment.

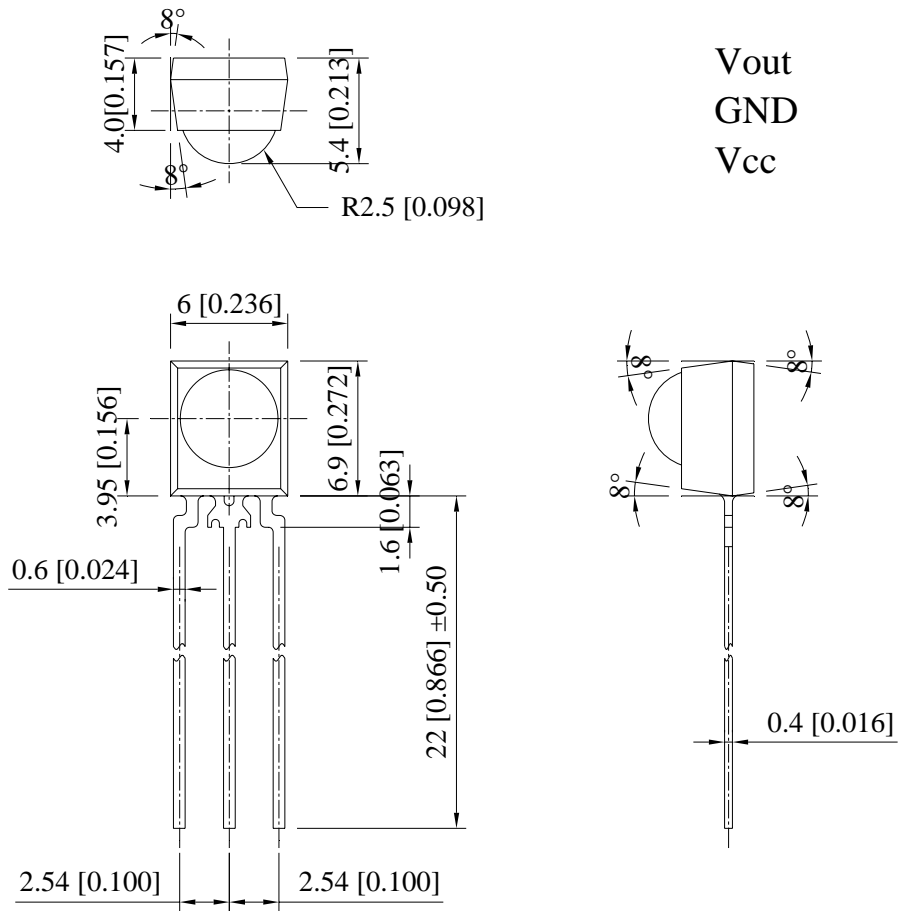
Package Dimension:

Vout
GND
Vcc

Part No.	Chip Material	Lens Color	Source Color
M6038	Silicon	Black	Infrared Receiver

Notes:

1. All dimensions are in millimeters (inches).
2. Tolerance is ± 0.25mm (.010") unless otherwise specified.
3. Specifications are subject to change without notice.

Absolute Maximum Ratings at Ta=25

Parameters	Symbol	Value	Unit	Condition
Power Dissipation	PD	50	mW	Ta≤85
Supply Voltage	V _{CC}	-0.30 ~ +6.00	V	Pin1
Operating Current	I _C	3.00	mA	Pin1
Collector-Emitter Voltage	V _{CEO}	30	V	
Emitter-Collector-Voltage	V _{ECO}	5	V	
Operating Temperature	T _{OPR}	-40~ +85		
Storage Temperature	T _{STG}	-40~ +100		
Soldering Temperature [4mm (.157") from mold body]	T _{SOL}	260		t≤10s

Electrical Optical Characteristics at (Ta=25 , Vcc=5V, f0=38KHz)

Parameters	Symbol	Min.	Type	Max.	Unit	Condition
Power Supply Voltage	V _{CC}	2.70	5.00	5.50	V	
Dissipation Current	I _{CC}	---	1.00	1.50	mA	V _{CC} =5V, Ev=0
Static State Current	I _{CE}	---	---	0.50	mA	No Signal Input
Collector Dark Current	I _{CEO}	---	---	100	nA	V _{CE} =20V, Ee=0mW/cm ²
Reception Angle *	2θ _{1/2}	---	90	---	Deg	
Peak Wavelength	λ _p	---	940	---	nm	
Modulated Frequency	f ₀	---	38	---	KHz	
Max. Voltage Gain	A _v	75	80	85	dB	F _{IN} =37.9kHz V _{IN} =30μV p-p KHz
BPF Bandwidth	f _{BW}	f ₀ -1.5	f ₀	f ₀ +1.5	KHz	-3Db Bandwidth
Reception Distance	L ₀	14	---	---	m	V _{CC} =5V, At the ray axis (Note 1)
	L ₁	12	---	---	m	
	L ₂	10	---	---	m	
Low Level Output Voltage	V _{OL}	---	---	0.25	V	Ev=0.5mw/m ² (Cycle=1.2ms) (Duty=50%)
High Level Output Voltage	V _{OH}	V _{CC} - 0.25	---	V _{CC}	V	
Low Output Pulse Width	T _{PWL}	300	600	900	μs	V _{IN} =50mVp-p
High Output Pulse Width	T _{PWH}	300	600	900	μs	V _{IN} =50mVp-p

Notes:

1. The ray receiving surface at a vertex and relation to the ray axis in the range of θ=0° and θ=45°.

2. A range from 30cm to the arrival distance. Average value of 50 pulses.

Typical Electrical / Optical Characteristics Curves
 (25 Ambient Temperature Unless Otherwise Noted)

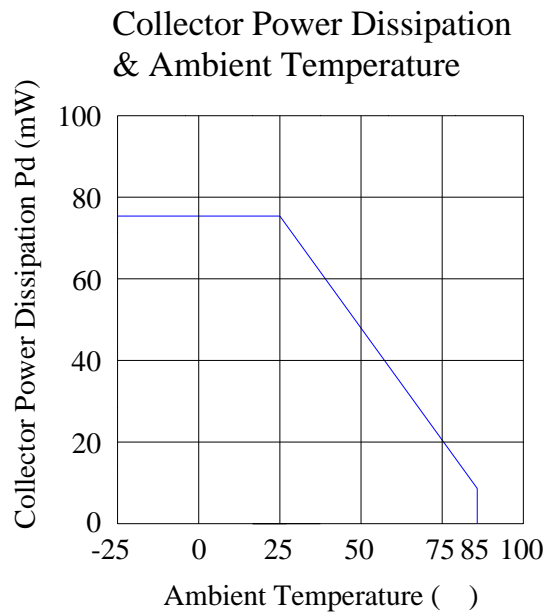
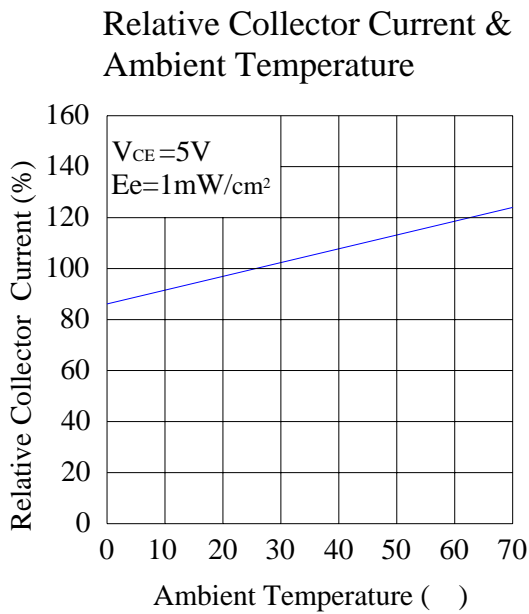
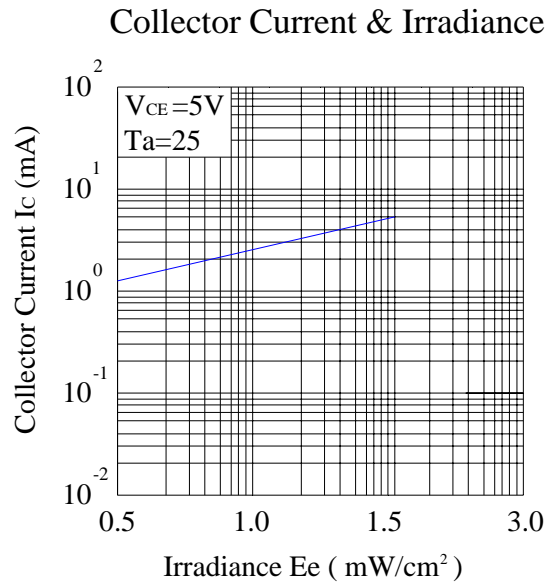
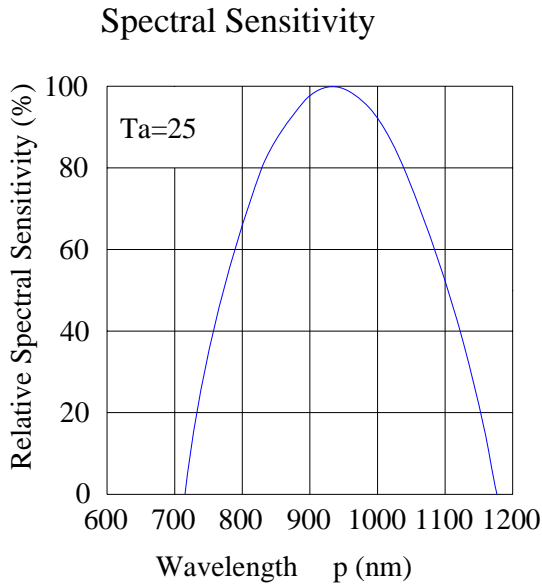



Collector Dark Current & Ambient Temperature

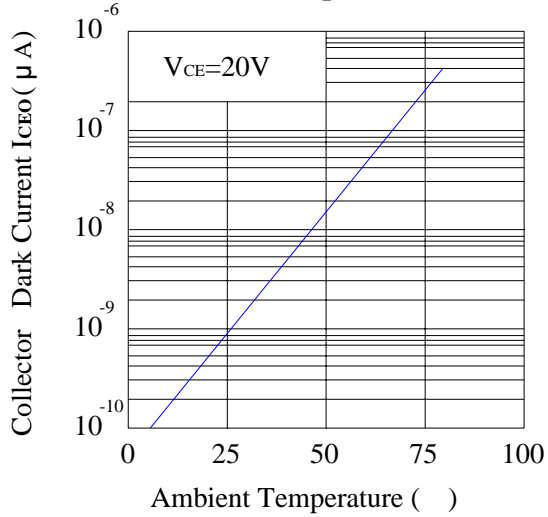

Collector Current & Collector-Emitter Voltage

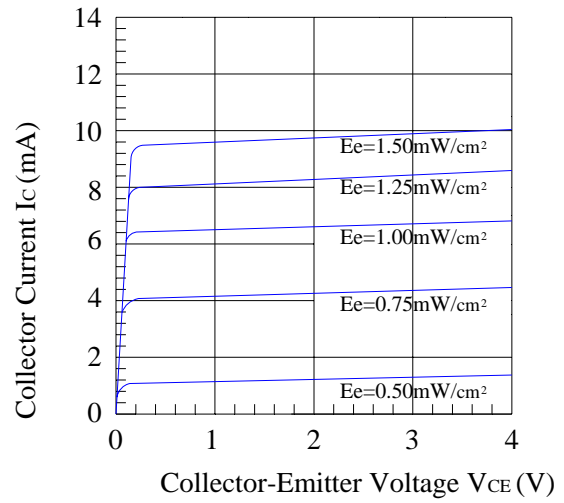

Reception Angle

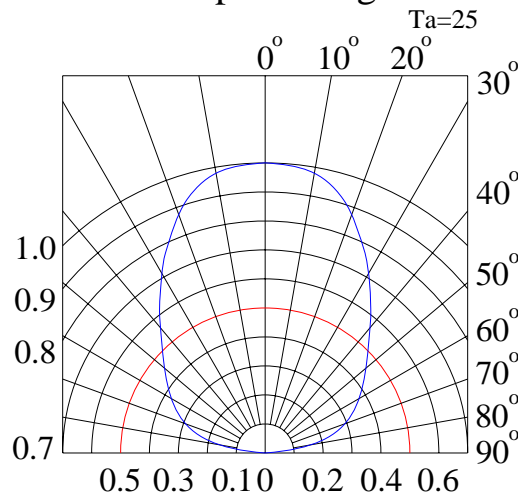

The test waveform:

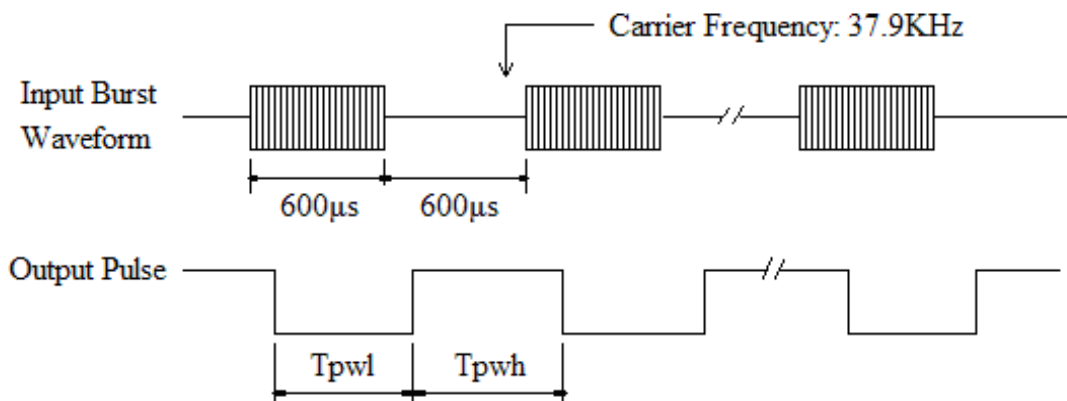

Electrical truth chart:

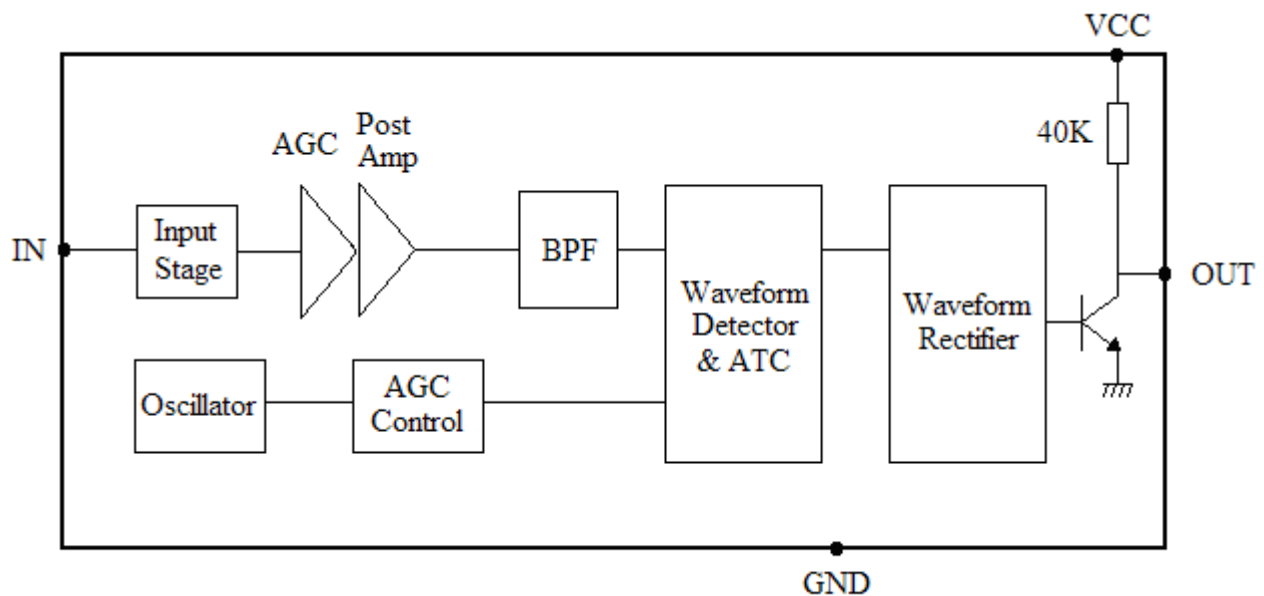

Applications:

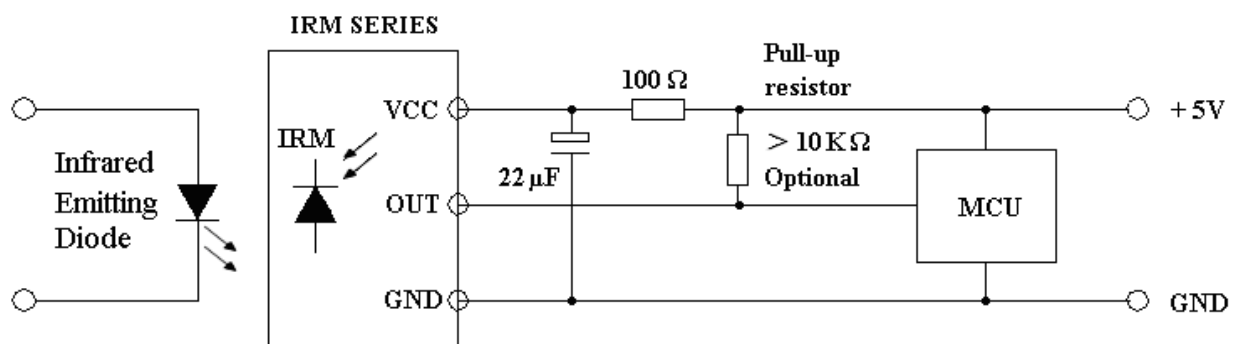

RC Filter should be connected closely between Vcc pin and GND pin.

Test Method:

The specified electro-optical characteristics is satisfied under the following conditions at the controllable distance.

Measurement place.

A place that is nothing of extreme light reflected in the room.

External light.

Project the light of ordinary white fluorescent lamps which are not high frequency lamps and must be less than 10Lux at the module surface ($E_e \leq 10\text{Lux}$).

Standard transmitter

A transmitter whose output is so adjusted as to $V_o=400\text{mVp-p}$ and the output wave form shown in Fig.-1. According to the measurement method shown in Fig.-2 the standard transmitter is specified. However, the infrared photodiode to be used for the transmitter should be $\lambda_p=940\text{nm}$, $\Delta\lambda=50\text{nm}$. Also, photodiode is used of PD516AD ($V_R=5\text{V}$). (Standard light / Light source temperature 2856°K).

Measuring system.

According to the measuring system shown in Fig.-3.

Fig.-1 Transmitter Wave Form

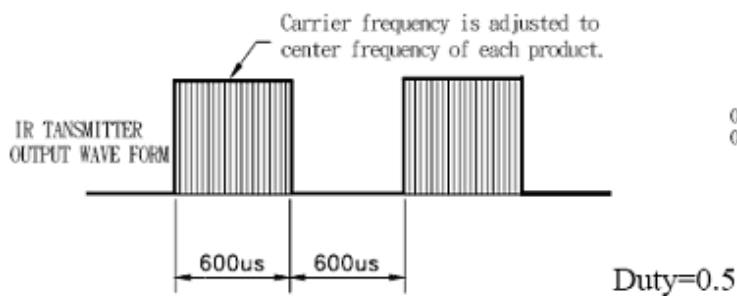

D.U.T output Pulse

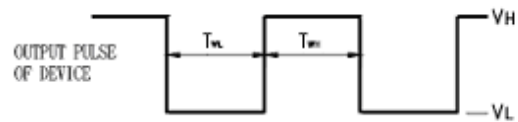

Fig.-2 Measuring Method

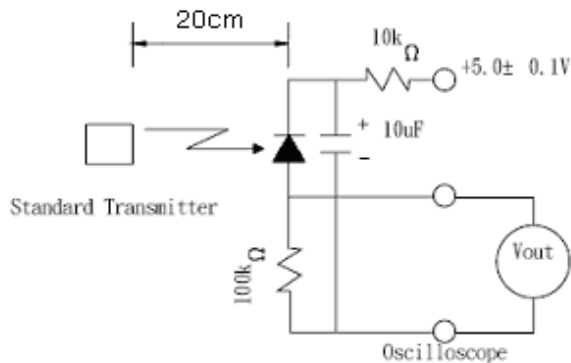
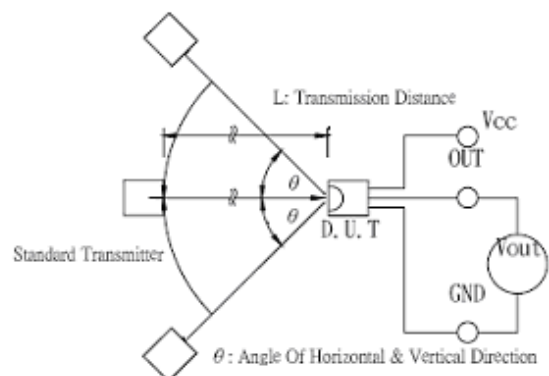

Fig.-3 Measuring System



Reliability Test Items And Conditions:

The reliability of products shall be satisfied with items listed below.

Confidence level: 90%.

LTPD: 10%.

No.	Test Items	Test Conditions	Failure Judgment Criteria	Samples(n) Defective(c)
1	Temperature Cycle	1 cycle -25 ∫ +85 (30min) (5min) (30min) 300 cycle test	L0 L×0.8 L45 L×0.8 L: Lower Specification Limit	n=22, c=0
2	High Temperature Test	Temp: +85 Vcc: 5V 1000hrs		n=22, c=0
3	Low Temperature Storage	Temp: -25 1000hrs		n=22, c=0
4	High Temperature High Humidity	Ta: 85 , RH:85% 1000hrs		n=22, c=0
5	Solder Heat	Temp: 260±5 10sec 4mm From the bottom of the package.		n=22, c=0

Please read the following notes before using the product:

1. Over-current-proof

Customer must apply resistors for protection, otherwise slight voltage shift will cause big current change (Burn out will happen).

2. Storage

2.1 Do not open moisture proof bag before the products are ready to use.

2.2 Before opening the package, the LEDs should be kept at 30 °C or less and 80%RH or less.

2.3 The LEDs should be used within a year.

2.4 After opening the package, the LEDs should be kept at 30 °C or less and 60%RH or less.

2.5 The LEDs should be used within 168 hours (7 days) after opening the package.

3. Soldering Iron

Each terminal is to go to the tip of soldering iron temperature less than 260 °C for 5 seconds within once in less than the soldering iron capacity 25W. Leave two seconds and more intervals, and do soldering of each terminal. Be careful because the damage of the product is often started at the time of the hand solder.

4. Soldering

When soldering, for Lamp without stopper type and must be leave a minimum of 3mm clearance from the base of the lens to the soldering point.

To avoided the Epoxy climb up on lead frame and was impact to non-soldering problem, dipping the lens into the solder must be avoided.

Do not apply any external stress to the lead frame during soldering while the LED is at high temperature.

Recommended soldering conditions:

Soldering Iron		Wave Soldering	
Temperature	300 Max.	Pre-heat	100 Max.
Soldering Time	3 sec. Max. (one time only)	Pre-heat Time	60 sec. Max.
		Solder Wave	260 Max.
		Soldering Time	5 sec. Max.

Note: Excessive soldering temperature and / or time might result in deformation of the LED lens or catastrophic failure of the LED.

5. Repairing

Repair should not be done after the LEDs have been soldered. When repairing is unavoidable, a double-head soldering iron should be used. It should be confirmed beforehand whether the characteristics of the LEDs will or will not be damaged by repairing.

6. Caution in ESD

Static Electricity and surge damages the LED. It is recommended to use a wrist band or anti-electrostatic glove when handling the LED. All devices equipment and machinery must be properly grounded.