

Infrared Remote-Control Receiver Module  
Technical Data Sheet

Part No.: M338S-P25



## Features:

- Photo detector and preamplifier in one package.
- High photo sensitivity.
- Low power waste.
- Fast response time.
- Small junction capacitance.
- Improved inner shielding against electrical field disturbance.
- TTL and CMOS compatibility.
- Improved immunity against ambient light.
- The product itself will remain within RoHS compliant version.

## Descriptions:

The M338S is miniaturized receivers for infrared remote control systems with the high speed PIN phototransistor and the full wave band preamplifier.

- Infrared applied system receiver.
- High anti-jamming ability.
- Wide operating voltage extension: 2.70~5.50V.
- The type operating distance is 12 meters.

## Applications:

- Infrared applied system.
- AV instruments such as Audio, TV, VCR, CD, MD, etc.
- CATV set top boxes.
- The other equipments with wireless remote control.
- Home appliances such as Air-conditioner, Fan, etc.
- Multi-media Equipment.
- Light detecting portion of remote control.

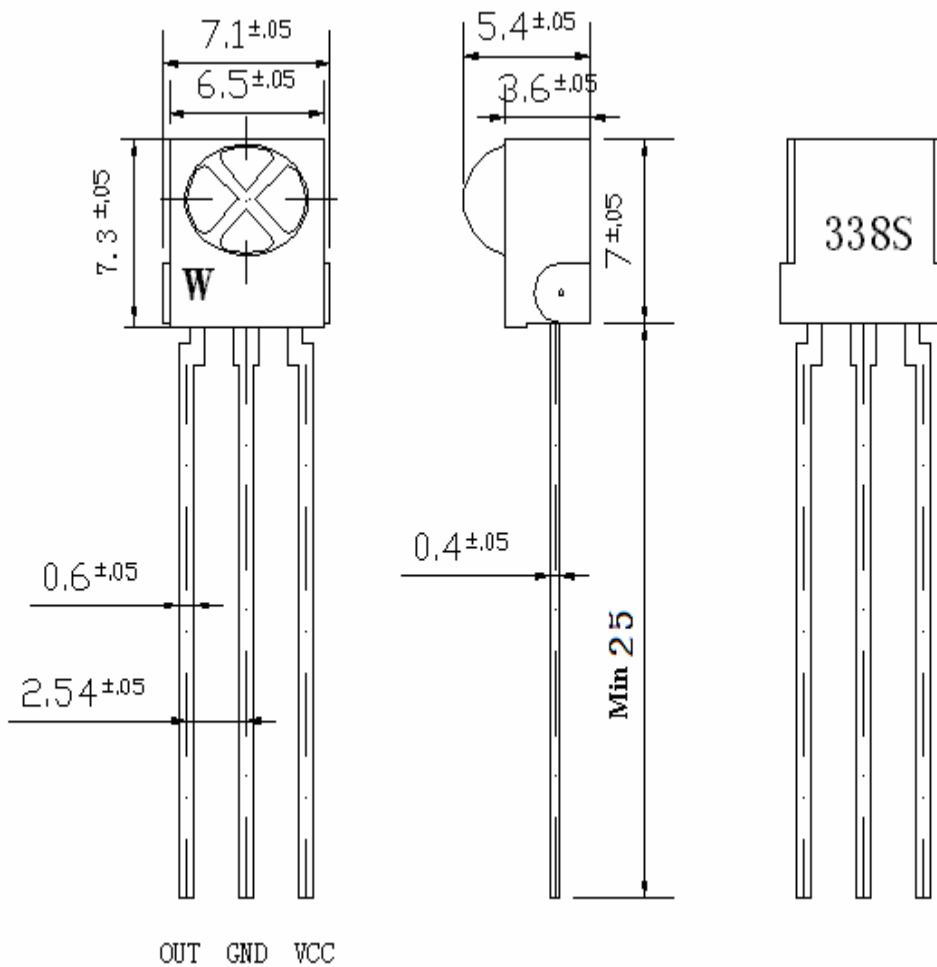
**Package Dimension:**

Part No.	Material		Color	Source Color
M338S-P25	Chip	Silicon	---	Infrared Receiver
	Lead Frame	SPCC	Silver White	---
	Compound	Epoxy	Black	---

**Notes:**

1. All dimensions are in millimeters (inches).
2. Tolerance is  $\pm 0.25\text{mm}$  (.010") unless otherwise specified.
3. Specifications are subject to change without notice.

### Absolute Maximum Ratings at Ta=25

Item	Symbol	Value	Unit
Supply Voltage	Vcc	-0.30~7.50	V
Operating Temperature	Topr	-40 to +80	
Storage Temperature	Tstg	-40 to +85	
Soldering Temperature	Tsol	260 for 5 Seconds	

### Electrical Optical Characteristics at (Ta=25 , Vcc=5V, fo=38KHz)

Parameters	Symbol	Min.	Typ.	Max.	Unit	Test Condition
Power Supply Voltage	V <sub>CC</sub>	2.70	---	5.50	V	
Dissipation Current	I <sub>CC</sub>	0.60	0.70	0.80	mA	V <sub>CC</sub> =3.30V
Static State Current	I <sub>CE</sub>	0.10	---	0.50	mA	No Signal Input
Reception Angle *	2θ <sub>1/2</sub>	---	90	---	Deg	
Peak Wavelength	λ <sub>p</sub>	---	940	---	nm	
Modulated Frequency	f <sub>0</sub>	---	37.9	---	KHz	
BMP Width	f <sub>BW</sub>	2.0	3.5	5.0	KHz	-3Db Bandwidth
Reception Distance	L	10	12	---	m	
Low Level Output Voltage	V <sub>OL</sub>	---	0.20	0.40	V	V <sub>IN</sub> =0, V <sub>CC</sub> =5V
High Level Output Voltage	V <sub>OH</sub>	4.80	5.00	---	V	V <sub>CC</sub> =5V
Low Output Pulse Width	T <sub>PWL</sub>	500	600	700	μs	V <sub>IN</sub> =50mVp-p
High Output Pulse Width	T <sub>PWH</sub>	1600	1700	1800	μs	V <sub>IN</sub> =50mVp-p

#### Notes:

1. The ray receiving surface at a vertex and relation to the ray axis in the range of θ=0° and θ=45°.

2. A range from 30cm to the arrival distance. Average value of 50 pulses.

Typical Electrical / Optical Characteristics Curves  
 (25 Ambient Temperature Unless Otherwise Noted)

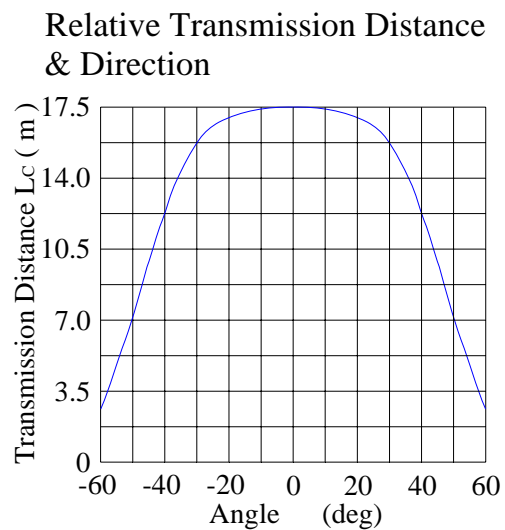
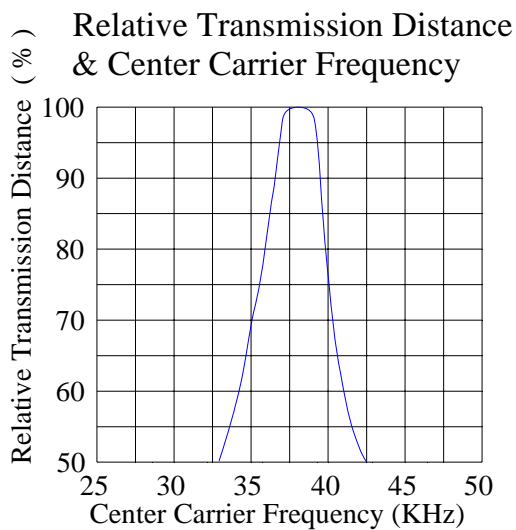
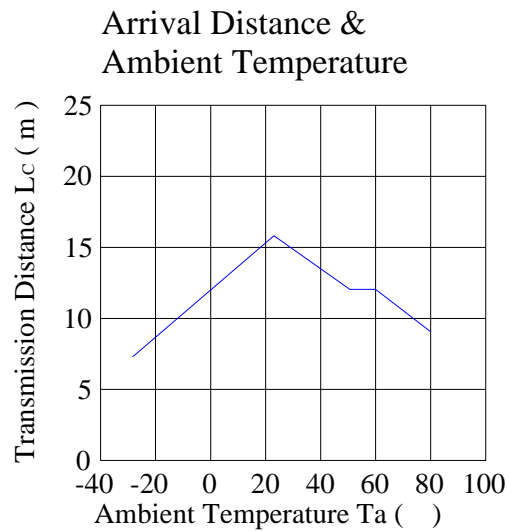
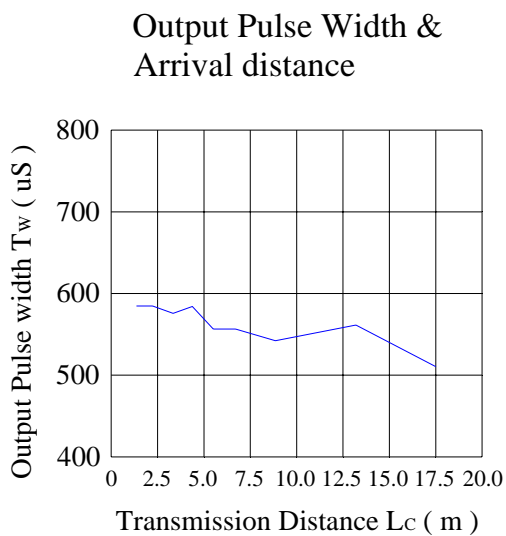
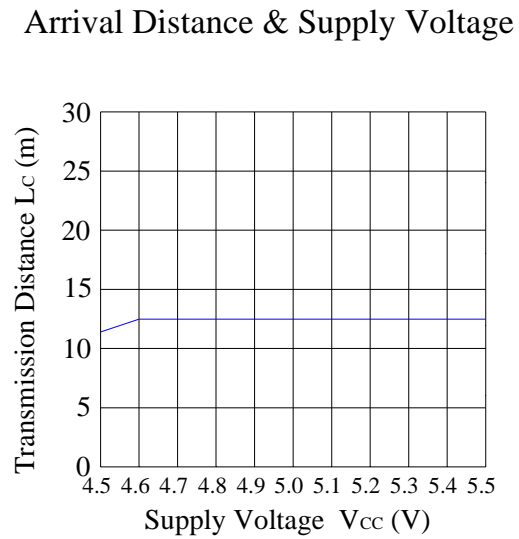
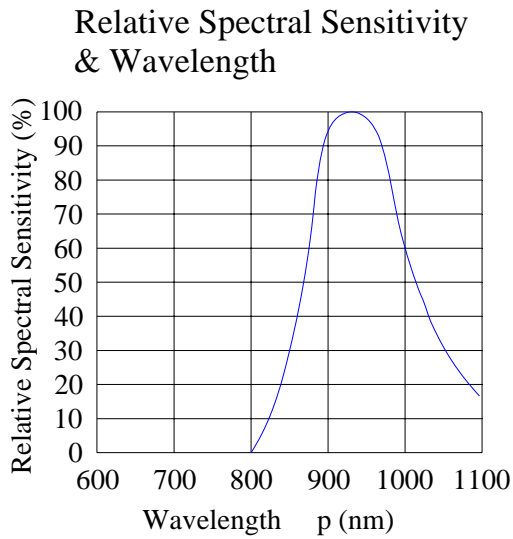

### Test Wave Form:

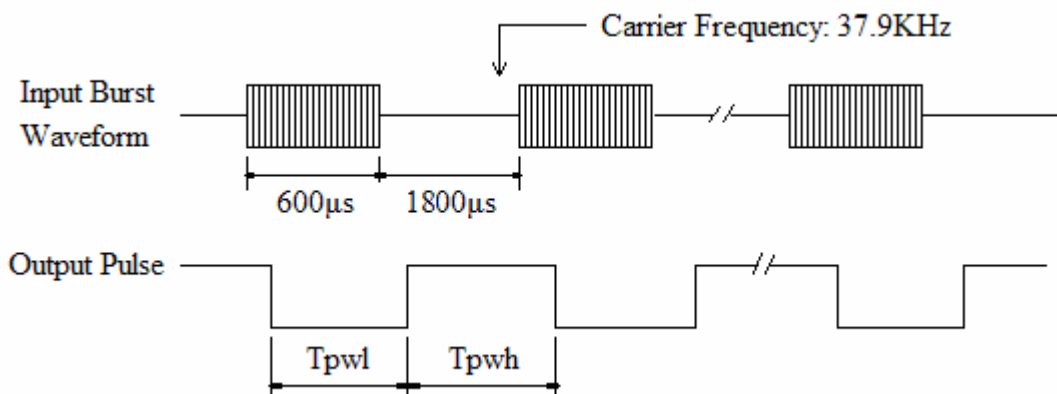

### Electrical Truth Chart:

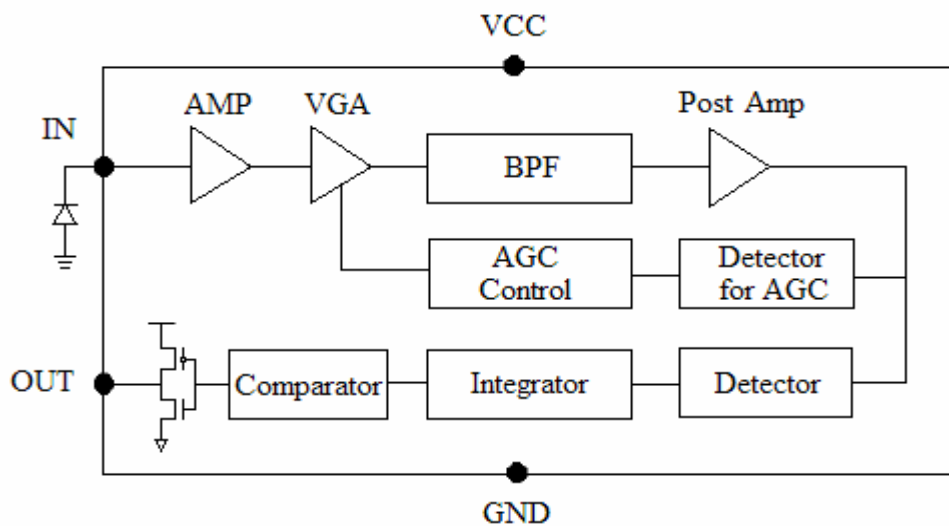

### Applications Circuit:

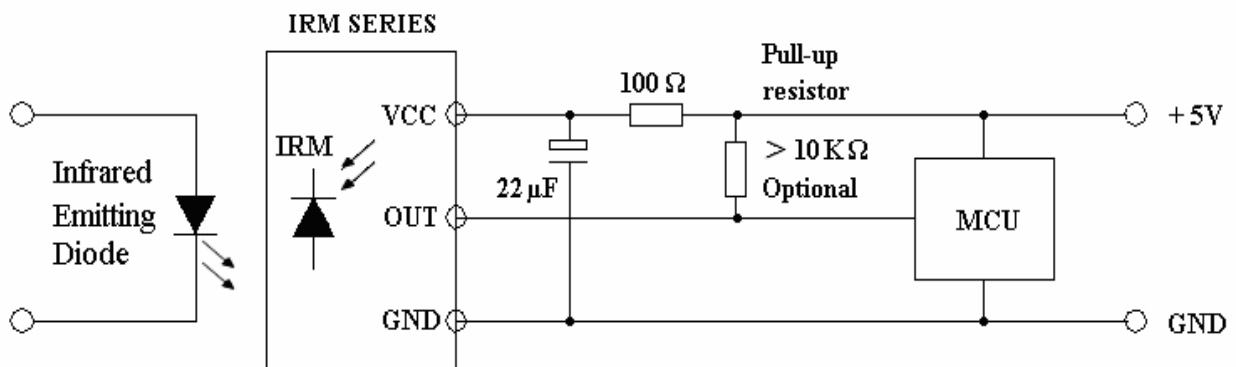

RC Filter should be connected closely between Vcc pin and GND pin.

## Test Method:

The specified electro-optical characteristics is satisfied under the following conditions at the controllable distance.

Measurement place.

A place that is nothing of extreme light reflected in the room.

External light.

Project the light of ordinary white fluorescent lamps which are not high frequency lamps and must be less then 10 Lux at the module surface ( $E_e = 10\text{Lux}$ ).

Standard transmitter

A transmitter whose output is so adjusted as to  $V_o=400\text{mVp-p}$  and the output wave form shown in Fig.-1. According to the measurement method shown in Fig.-2 the standard transmitter is specified. However, the infrared photodiode to be used for the transmitter should be  $\lambda_p=940\text{nm}$ ,  $\Delta\lambda=50\text{nm}$ . Also, photodiode is used of a PD ( $V_R=5\text{V}$ ). (Standard light / Light source temperature  $2856^\circ\text{K}$ ).

Measuring system.

According to the measuring system shown in Fig.-3.

Fig.-1 Transmitter Wave Form

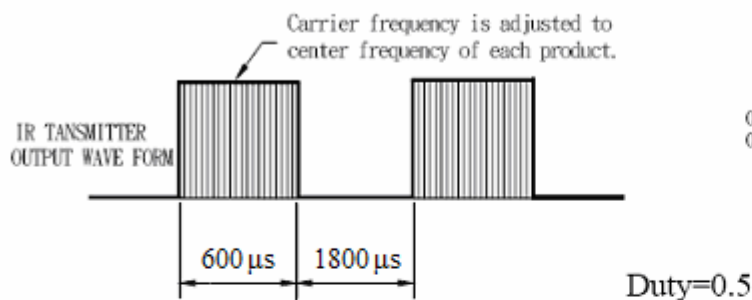

D.U.T output Pulse

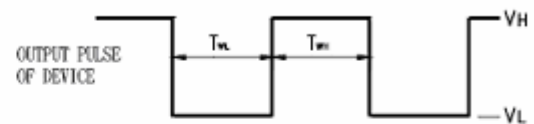

Fig.-2 Measuring Method

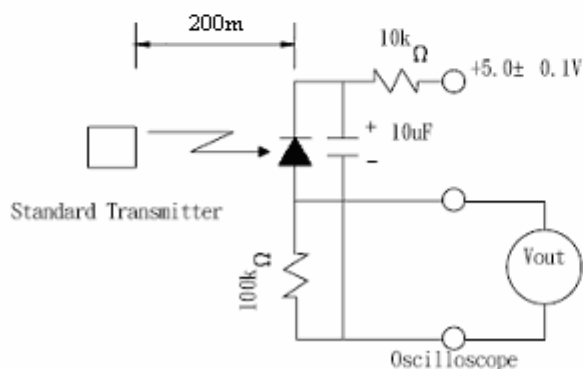
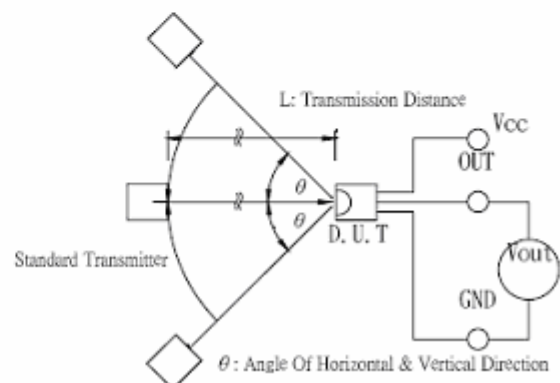

Fig.-3 Measuring System



## Reliability Test Items And Conditions:

The reliability of products shall be satisfied with items listed below.

Confidence level: 90%.

LTPD: 10%.

No.	Test Items	Test Conditions	Failure Judgment Criteria	Samples(n) Defective(c)
1	Temperature Cycle	1 cycle -25 ∫ +85 (30min) (5min) (30min) 300 cycle test	L0 L×0.8 L45 L×0.8  L: Lower Specification Limit	n=22, c=0
2	High Temperature Test	Temp: +85 Vcc: 5V 1000hrs		n=22, c=0
3	Low Temperature Storage	Temp: -25 1000hrs		n=22, c=0
4	High Temperature High Humidity	Ta: 85 , RH:85% 1000hrs		n=22, c=0
5	Solder Heat	Temp: 260±5 10sec 4mm From the bottom of the package.		n=22, c=0



Please read the following notes before using the product:

1. Over-current-proof

Customer must apply resistors for protection, otherwise slight voltage shift will cause big current change (Burn out will happen).

2. Storage

- 2.1 Do not open moisture proof bag before the products are ready to use.
- 2.2 Before opening the package, the LEDs should be kept at 30 °C or less and 80%RH or less.
- 2.3 The LEDs should be used within a year.
- 2.4 After opening the package, the LEDs should be kept at 30 °C or less and 60%RH or less.
- 2.5 The LEDs should be used within 168 hours (7 days) after opening the package.

3. Soldering Iron

Each terminal is to go to the tip of soldering iron temperature less than 260 °C for 5 seconds within once in less than the soldering iron capacity 25W. Leave two seconds and more intervals, and do soldering of each terminal. Be careful because the damage of the product is often started at the time of the hand solder.

4. Soldering

When soldering, for Lamp without stopper type and must be leave a minimum of 3mm clearance from the base of the lens to the soldering point.

To avoided the Epoxy climb up on lead frame and was impact to non-soldering problem, dipping the lens into the solder must be avoided.

Do not apply any external stress to the lead frame during soldering while the LED is at high temperature.

Recommended soldering conditions:

Soldering Iron		Wave Soldering	
Temperature	300 Max.	Pre-heat	100 Max.
Soldering Time	3 sec. Max. (one time only)	Pre-heat Time	60 sec. Max.
		Solder Wave	260 Max.
		Soldering Time	5 sec. Max.

Note: Excessive soldering temperature and / or time might result in deformation of the LED lens or catastrophic failure of the LED.

5. Repairing

Repair should not be done after the LEDs have been soldered. When repairing is unavoidable, a double-head soldering iron should be used. It should be confirmed beforehand whether the characteristics of the LEDs will or will not be damaged by repairing.

6. Caution in ESD

Static Electricity and surge damages the LED. It is recommended to use a wrist band or anti-electrostatic glove when handling the LED. All devices equipment and machinery must be properly grounded.