

1206 Package Phototransistor  
Technical Data Sheet

Part No.: S150PTD-1A

## Features:

- ◇ Fast response time.
- ◇ High photo sensitivity.
- ◇ Small junction capacitance.
- ◇ Package in 8mm tape on 7" diameter reel.
- ◇ The product itself will remain within RoHS compliant Version.

## Descriptions:

- ◇ The S150PT is a high speed and high sensitive silicon NPN phototransistor in miniature SMD package which is molded in a black epoxy with flat top view lens.
- ◇ Due to its black epoxy, the device is spectrally matched to visible and infrared emitting diode.

## Applications:

- ◇ Automatic door sensor.
- ◇ Infrared applied system.
- ◇ Counters and sorters.
- ◇ Encoders.
- ◇ Floppy disk drive.
- ◇ Optoelectronic switch.
- ◇ Video camera, tape and card readers.
- ◇ Position sensors.
- ◇ Copier.
- ◇ Game machine.

### Package Dimension:

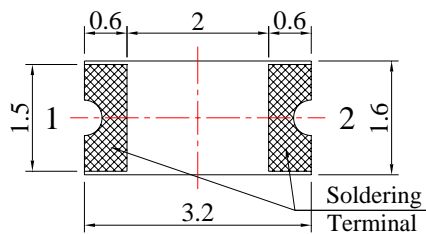
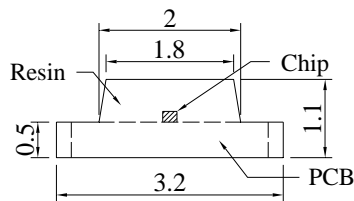
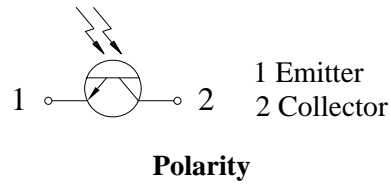
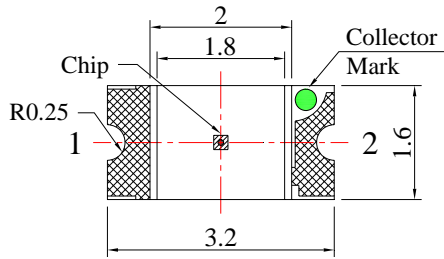

### Recommended Soldering Pad Dimensions

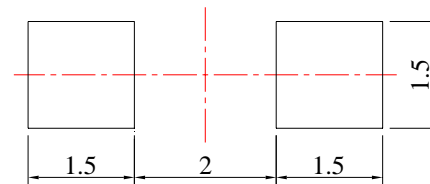

Unit: mm  
Tolerance:  $\pm 0.10\text{mm}$

Part No.	Chip Material	Lens Color	Source Color
S150PTD-1A	Silicon	Black	Phototransistor

### Notes:

1. All dimensions are in millimeters (inches).
2. Tolerance is  $\pm 0.10\text{ mm}$  (.004") unless otherwise specified.
3. Specifications are subject to change without notice.

**Absolute Maximum Ratings (Ta=25°C)**

Parameters	Symbol	Rating	Unit
Power Dissipation At (or below) 25°C free Air Temperature	P <sub>D</sub>	75	mW
Collector-Emitter Voltage	V <sub>CEO</sub>	30	V
Emitter-Collector-Voltage	V <sub>ECO</sub>	5	V
Collector Current	I <sub>C</sub>	20	mA
Operating Temperature	Topr	-40°C to +80°C	
Storage Temperature	Tstg	-40°C to +85°C	
Soldering Temperature	Tsol	260°C for 5 Seconds	

**Electrical Optical Characteristics at Ta=25°C**

Parameters	Symbol	Min.	Typ.	Max.	Unit	Condition
Collector-Emitter Breakdown Voltage	BV <sub>CEO</sub>	30	---	---	V	I <sub>C</sub> =100μA, Ee=0mW/cm <sup>2</sup>
Emitter-Collector Breakdown Voltage	BV <sub>ECO</sub>	5	---	---	V	I <sub>E</sub> =100μA, Ee=0mW/cm <sup>2</sup>
Collector-Emitter Saturation Voltage	V <sub>CE(SAT)</sub>	---	---	0.40	V	I <sub>C</sub> =2mA, Ee=1mW/cm <sup>2</sup>
Collector Dark Current	I <sub>CEO</sub>	---	---	100	nA	V <sub>CE</sub> =20V, Ee=0mW/cm <sup>2</sup>
On State Collector Current	I <sub>C(ON)</sub>	0.10	0.50	---	mA	V <sub>CE</sub> =5V, Ee=1mW/cm <sup>2</sup>
Optical Rise Time (10% to 90%)	T <sub>R</sub>	---	15	---	μs	V <sub>CE</sub> =5V, I <sub>C</sub> =1mA, R <sub>L</sub> =1000Ω
Optical Fall Time (90% to 10%)	T <sub>F</sub>	---	15	---		
Reception Angle	2θ <sub>1/2</sub>	---	120	---	Deg	
Wavelength Of Peak Sensitivity	λ <sub>P</sub>	---	940	---	nm	
Rang Of Spectral Bandwidth	λ <sub>0.5</sub>	700	---	1200	nm	

### Typical Electrical / Optical Characteristics Curves (25°C Ambient Temperature Unless Otherwise Noted)

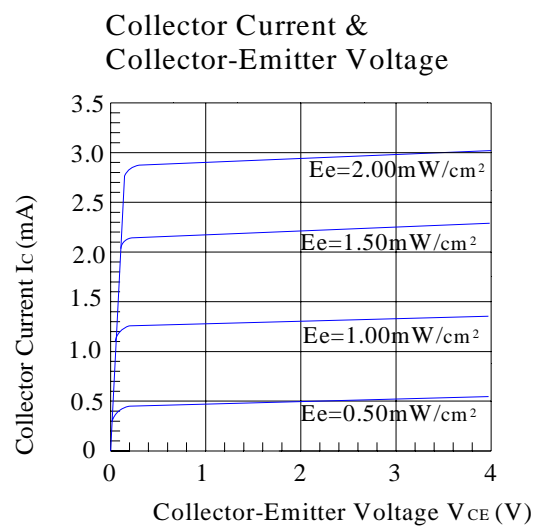
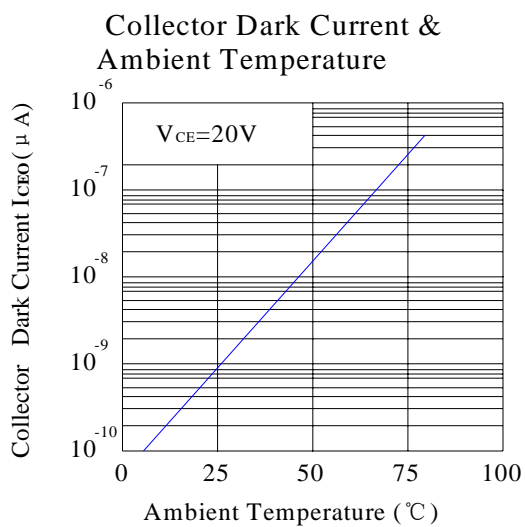
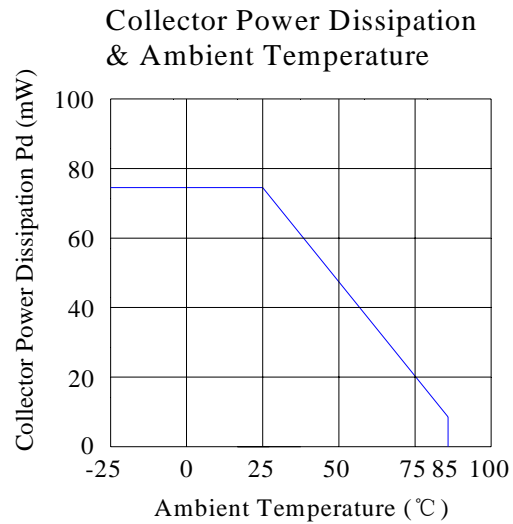
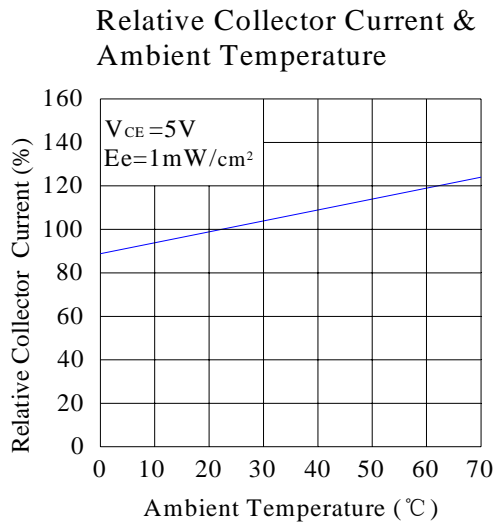
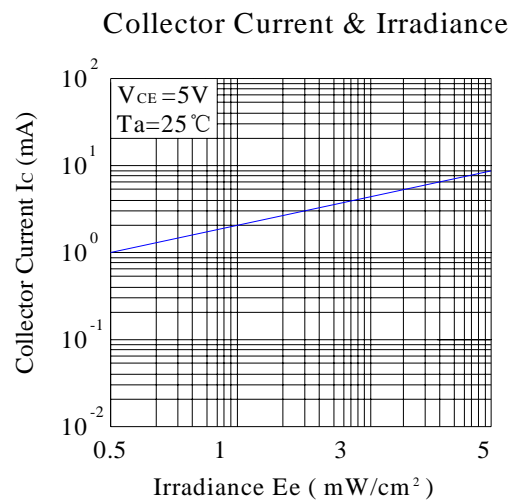
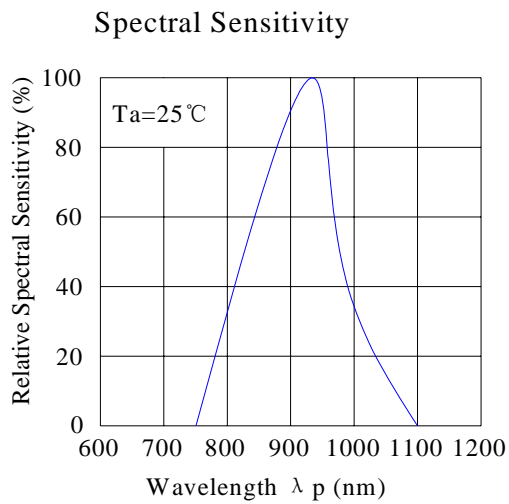

### Reliability Test Item And Condition:

The reliability of products shall be satisfied with items listed below:

Confidence level: 90%.

LTPD: 10%.

No.	Item	Test Conditions	Test Hours/ Cycles	Sample Sizes	Failure Judgment Criteria	Ac/ Re
1	Reflow Soldering	TEMP.: 260°C±5°C 5secs	6mins	22pcs	$I_{C(ON)} \leq L \times 0.8$  L: Lower Specification Limit	0/1
2	Temperature Cycle	H: +100°C 15mins ↑ 5 mins ↓ L: -40°C 15mins	50Cycles	22pcs		0/1
3	Thermal Shock	H: +100°C 15mins ↑ 10mins ↓ L: -10°C 5mins	50Cycles	22pcs		0/1
4	High Temperature Storage	TEMP.: +100°C	1000hrs	22pcs		0/1
5	Lower Temperature Storage	TEMP.: -40°C	1000hrs	22pcs		0/1
6	DC Operating Life	$V_{CE}=5V$	1000hrs	22pcs		0/1
7	High Temperature/ High Humidity	85°C / 85% R.H	1000hrs	22pcs		0/1

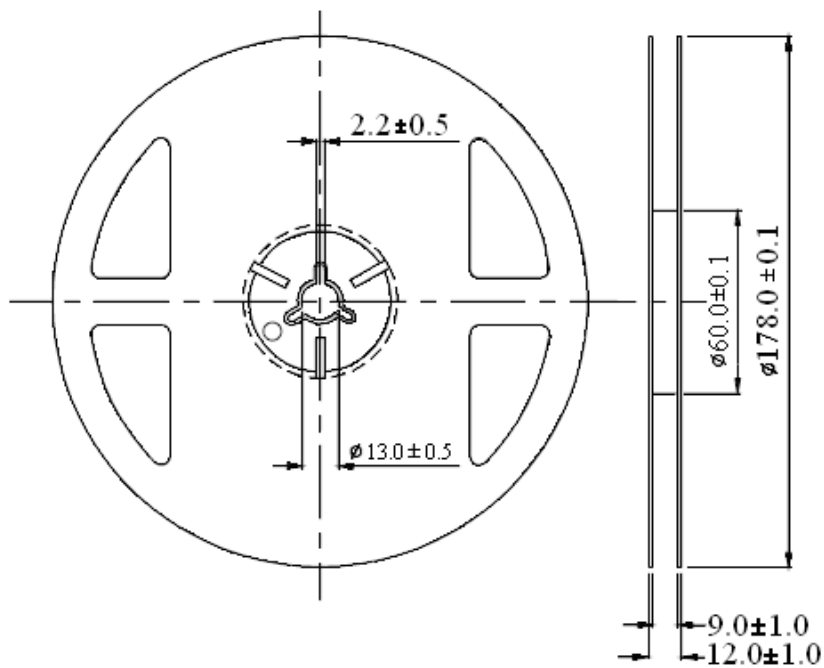
**Reel Dimensions:**

Unit: mm  
Tolerance:  $\pm 0.25\text{mm}$

**Carrier Tape Dimensions:**

Loaded quantity 3000 PCS Per reel.

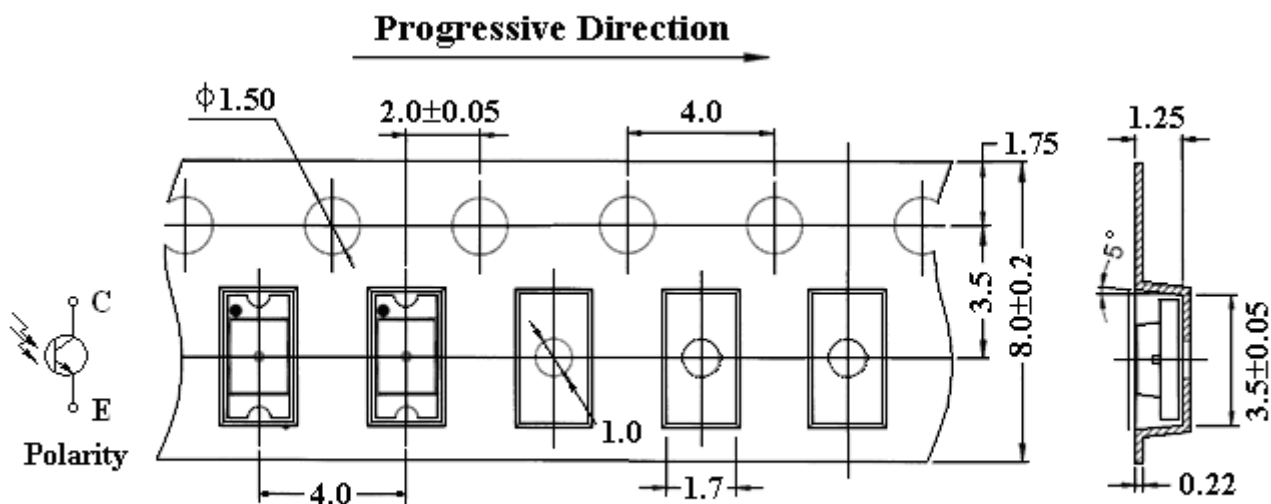

Unit: mm  
Tolerance:  $\pm 0.10\text{mm}$

Please read the following notes before using the product:

1. Over-current-proof

Customer must apply resistors for protection, otherwise slight voltage shift will cause big current change (Burn out will happen).

2. Storage

- 2.1 Do not open moisture proof bag before the products are ready to use.
- 2.2 Before opening the package, the LEDs should be kept at 30°C or less and 80%RH or less.
- 2.3 The LEDs should be used within a year.
- 2.4 After opening the package, the LEDs should be kept at 30°C or less and 60%RH or less.
- 2.5 The LEDs should be used within 168 hours (7 days) after opening the package.
- 2.6 If the moisture adsorbent material has fabled away or the LEDs have exceeded the storage time, baking treatment should be performed using the following conditions. Baking treatment: 60±5°C for 24 hours.

3. Soldering Condition

When soldering, for Lamp without stopper type and must be leave a minimum of 3mm clearance from the base of the lens to the soldering point.

To avoided the Epoxy climb up on lead frame and was impact to non-soldering problem, dipping the lens into the solder must be avoided.

Do not apply any external stress to the lead frame during soldering while the LED is at high temperature.

Recommended soldering conditions:

Soldering Iron		Wave Soldering	
Temperature	300°C Max.	Pre-heat	100°C Max.
Soldering Time	3 sec. Max. (one time only)	Pre-heat Time	60 sec. Max.
		Solder Wave	260°C Max.
		Soldering Time	5 sec. Max.

Note: Excessive soldering temperature and / or time might result in deformation of the LED lens or catastrophic failure of the LED.

4. Soldering Iron

Each terminal is to go to the tip of soldering iron temperature less than 260°C for 5 seconds within once in less than the soldering iron capacity 25W. Leave two seconds and more intervals, and do soldering of each terminal. Be careful because the damage of the product is often started at the time of the hand solder.

5. Repairing

Repair should not be done after the LEDs have been soldered. When repairing is unavoidable, a double-head soldering iron should be used (as below figure). It should be confirmed beforehand whether the characteristics of the LEDs will or will not be damaged by repairing.



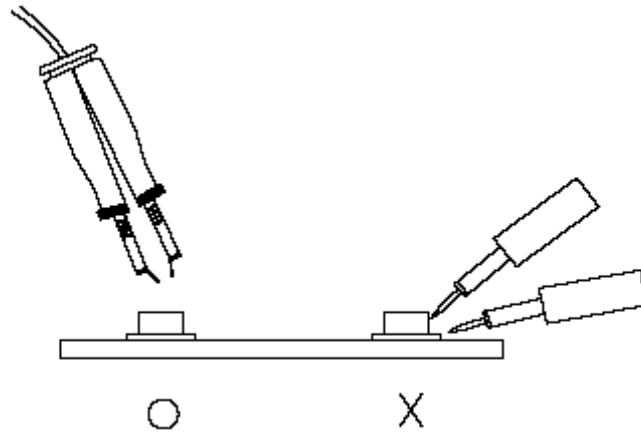

## 6. Caution in ESD

Static Electricity and surge damages the LED. It is recommended to use a wrist band or anti-electrostatic glove when handling the LED. All devices, equipment and machinery must be properly grounded.