

Infrared Receiver Module  
Technical Data Sheet

Part No.: LL-M138S

## Features:

- ◇ Photo detector and preamplifier in one package.
- ◇ High photo sensitivity.
- ◇ Improved inner shielding against electrical field disturbance.
- ◇ Improved immunity against ambient light.
- ◇ High protection ability against EMI.
- ◇ Circular lens to improve the receive characteristic.
- ◇ Line-up for various center carrier frequencies.
- ◇ Low voltage and low power consumption.
- ◇ Photodiode with integrated circuit.
- ◇ TTL and CMOS compatibility.
- ◇ Long reception distance.
- ◇ The product itself will remain within RoHS compliant version.

## Descriptions:

- ◇ The M138S is miniaturized receivers for infrared remote control systems with the high speed PIN phototransistor and the full wave band preamplifier.
- ◇ The PIN diode and preamplifier are assembled on lead frame, the epoxy package is designed as an IR filter.
- ◇ The demodulated output signal can directly be decoded by a microprocessor.
- ◇ The M138S is the standard IR remote control receiver series, supporting all major transmission codes.

## Applications:

- ◇ Infrared applied system.
- ◇ Optical switch.
- ◇ Light detecting portion of remote control.
- ◇ AV instruments such as Audio, TV, VCR, CD, MD, etc.
- ◇ CATV set top boxes.
- ◇ The other equipments with wireless remote control.
- ◇ Home appliances such as Air-conditioner, Fan, etc.
- ◇ Multi-media Equipment.

### Package Dimension:

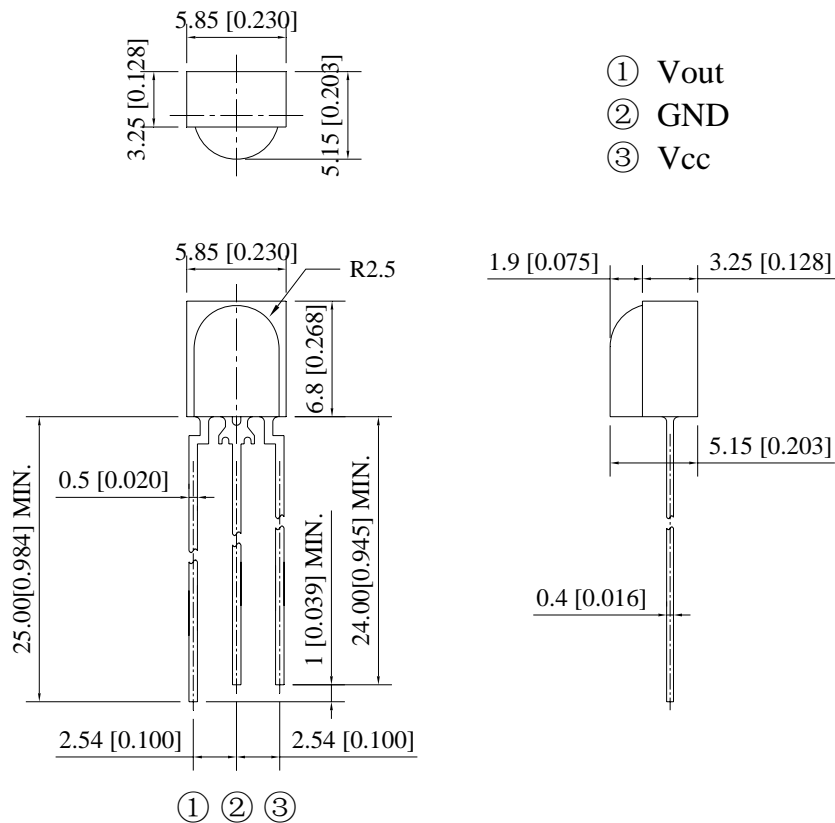

Part No.	Material		Color	Source Color
LL-M138S	Chip	Silicon	---	Infrared Receiver
	Lead Frame	SPCC	Silver White	---
	Compound	Epoxy	Black	---

### Notes:

1. All dimensions are in millimeters (inches).
2. Tolerance is  $\pm 0.25$  mm (.010") unless otherwise specified.
3. Specifications are subject to change without notice.

**Absolute Maximum Ratings at Ta=25°C**

Item	Symbol	Value	Unit	Notice
Supply Voltage	Vcc	-0.30~7.50	V	
Operating Temperature	Topr	-25 ~ +85	°C	
Storage Temperature	Tstg	-40 ~ +125	°C	
Soldering Temperature	Tsol	260	°C	At the position of 4mm from the bottom of the package within 5 seconds.

**Electrical Optical Characteristics at (Ta=25°C, Vcc=5V, fo=38 KHz)**

Parameters	Symbol	Min.	Typ.	Max.	Unit	Test condition
Power Supply Voltage	V <sub>CC</sub>	2.70	5.00	5.50	V	
Dissipation Current	I <sub>CC</sub>	0.60	0.70	0.80	mA	
Static Collector Current	I <sub>CEO</sub>	0.10	---	0.50	mA	No Signal Input
Reception Distance	L	10	12	---	m	
Reception Angle	2θ <sub>1/2</sub>	---	90	---	Deg	
Carrier Frequency	f <sub>0</sub>	---	37.9	----	KHz	
BMP Width	f <sub>BW</sub>	2.00	3.50	5.00	KHz	-3Db Bandwidth
Low Level Output Voltage	V <sub>OL</sub>	---	0.20	0.40	V	V <sub>in</sub> =0V, V <sub>CC</sub> =5V
High Level Output Voltage	V <sub>OH</sub>	4.80	5.00	---	V	V <sub>CC</sub> =5V
Output Pulse Width	V <sub>PWL</sub>	500	600	700	μS	V <sub>in</sub> =50mV <sub>p-p</sub>
	V <sub>PWH</sub>	1600	1700	1800	μS	V <sub>in</sub> =50mV <sub>p-p</sub>

**Notes:**

1. All the above tests are done indoors without any sunlight: Being disturbed in 1 metre distance over the 40W fluorescent lamp or by 200Lux incandescence lamps.

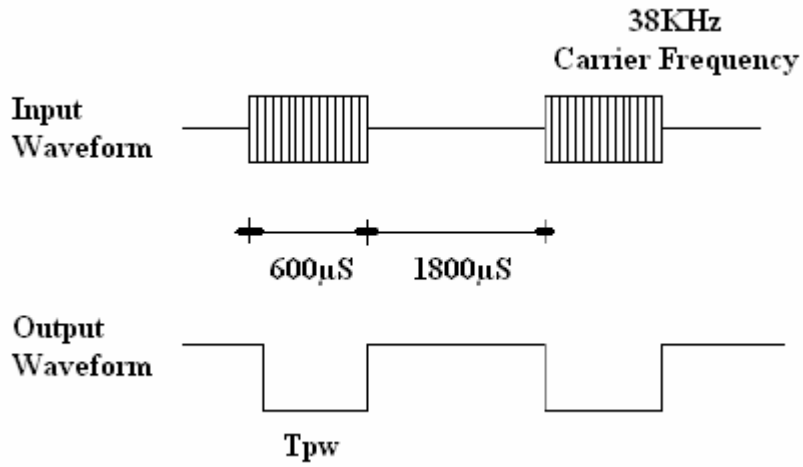
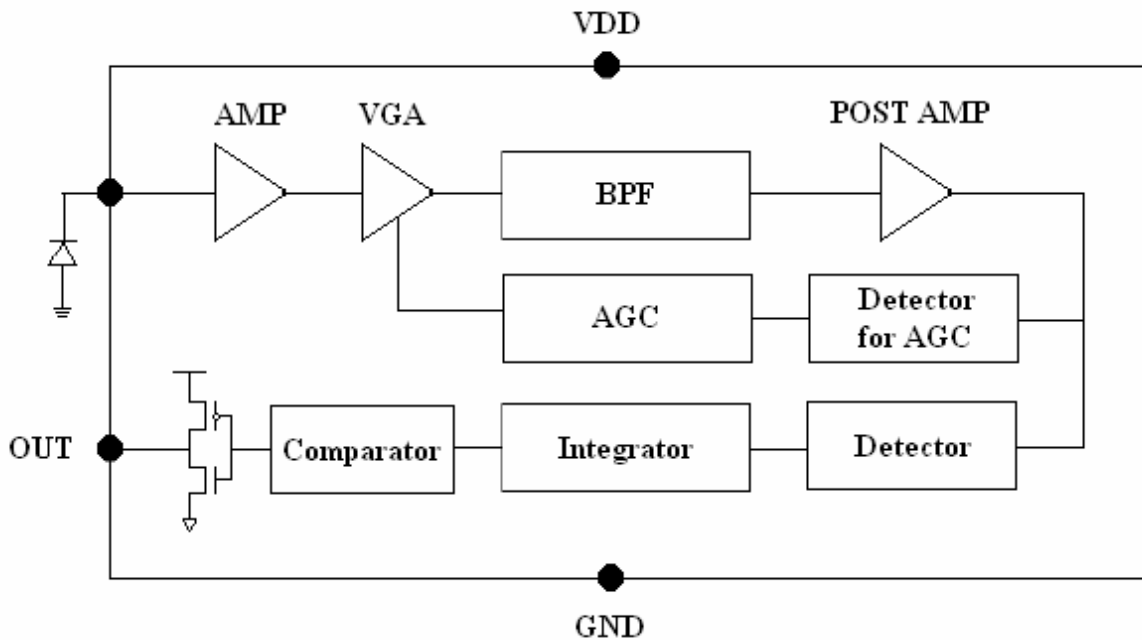
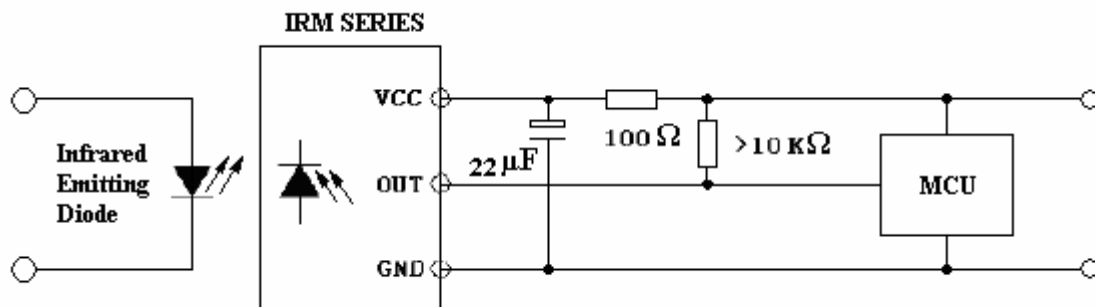
**Test Waveform:**

**Block Diagram:**

**Applications Circuit:**

## Reliability Test Items And Conditions:

The reliability of products shall be satisfied with items listed below:

Confidence level: 90%.

LTPD: 10%.

No.	Test Items	Test Conditions	Failure Judgement Criteria	Samples(n) ) Defective(c) )
1	Temperature cycle	1 cycle -25°C ∫ +85°C (30min) (5min) (30min) 300 cycle test	$L0 \cong L \times 0.8$ $L45 \cong L \times 0.8$  L: Lower Specification Limit	n=22, c=0
2	High temperature test	Temp: +85°C Vcc: 5V 1000hrs		n=22, c=0
3	Low temperature storage	Temp: -25°C 1000hrs		n=22, c=0
4	High temperature High humidity	Ta: 85°C, RH:85% 1000hrs		n=22, c=0
5	Solder heat	Temp: 260±5°C 10sec 4mm From the bottom of the package.		n=22, c=0

Please read the following notes before using the product:

1. Over-current-proof

Customer must apply resistors for protection, otherwise slight voltage shift will cause big current change (Burn out will happen).

2. Storage

2.1 Do not open moisture proof bag before the products are ready to use.

2.2 Before opening the package, the Infrared Receiver Module should be kept at 30°C or less and 90%RH or less.

2.3 The Infrared Receiver Module should be used within a year.

2.4 After opening the package, the Infrared Receiver Module should be kept at 30°C or less and 70%RH or less.

2.5 The Infrared Receiver Module should be used within 168 hours (7 days) after opening the package.

2.6 If the moisture adsorbent material (silica gel) has fabled away or the Infrared Receiver Module have exceeded the storage time, baking treatment should be performed using the following conditions: Baking treatment: 60±5°C for 24 hours.

3. Soldering Iron

Each terminal is to go to the tip of soldering iron temperature less than 260°C for 5 seconds within once in less than the soldering iron capacity 25W. Leave two seconds and more intervals, and do soldering of each terminal. Be careful because the damage of the product is often started at the time of the hand solder.

4. Repairing

Repair should not be done after the Infrared Receiver Module have been soldered. When repairing is unavoidable, a double-head soldering iron should be used (as below figure). It should be confirmed beforehand whether the characteristics of the Infrared Receiver Module will or will not be damaged by repairing.

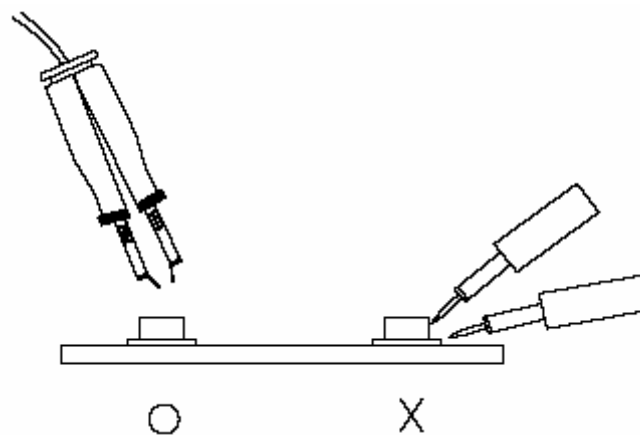

## 5. Caution in ESD

Static Electricity and surge damages the Infrared Receiver Module. It is recommended to use a wrist band or anti-electrostatic glove when handling the Infrared Receiver Module. All devices, equipment and machinery must be properly grounded.